

RooStick User Guide

Revision 1.1

Introduction

RooStick provides a serial interface to connect a PC directly to the Roomba using the USB port. It is powered by the Silicon Lab CP2103 chip and comes with drivers for Windows, Mac OS, and Linux. RooStick is ideal for placing a laptop, notebook, or tablet PC directly on top of Roomba. Installing the driver software provided creates a virtual Comm Port on your PC. Any program that can talk to the serial port is able to send commands to the Roomba as well as receive information from it.

1. *Installing the RooStick*

Note: RooStick requires a Male-2-Male 7pin mini-din cable or similar for connecting to Roomba. The latest RooStick driver can be found on the product page -

<http://www.roombadevtools.com/ProductCart/pc/viewPrd.asp?idcategory=4&idproduct=3>

1. Download the latest driver from the product page.
2. Install the driver (Note: Make sure the RooStick is NOT plugged into the computer until after installation completes.)
3. Plug RooStick into any USB port on your computer.
4. Note the virtual Comm Port that was created when RooStick is plugged in (For Windows users, the port number can be found in Control Panel → System → Hardware → Device Manager → Ports). This is the port that you must use to communicate with Roomba.
5. Use a Male-to-Male DIN7 cable to connect RooStick to Roomba.
6. You can now begin to communicate with Roomba using your PC over a serial connection.

An already available program for Roomba communication is the SCI Tester which can be found in the software section of the company webpage. Please refer to Roomba SCI documentation for information on SCI commands - http://www.roombadevtools.com/productcart/pc/docs/docs_roombasci.pdf

2. Interface

The TX and RX of the USB module on RooStick are connected to the RX and TX pins of Roomba respectively. The user controls the TX and RX pins of the USB module through the controlling application. A falling edge on the DD pin causes Roomba activate. Figure 1 shows the block diagram of the system.

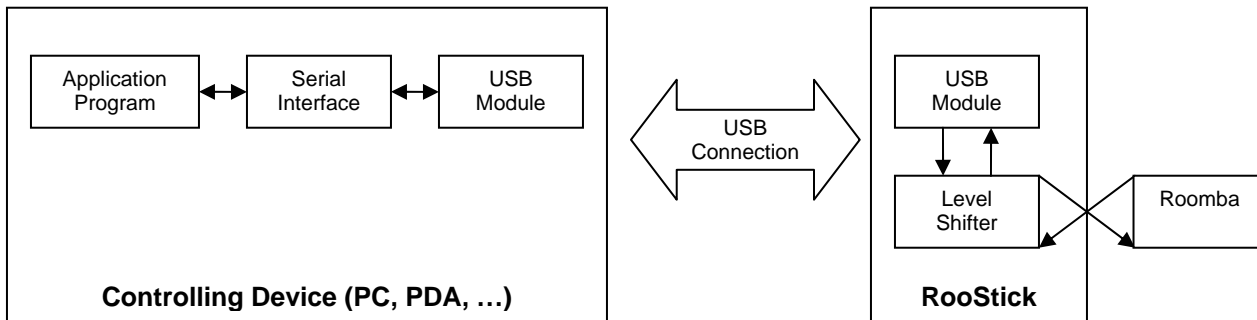

Figure 1. Block Diagram of the RooStick System and Communication with the Controlling Application

The interface between RooStick and Roomba is through a 5 pin connector, which connects to the 5 pins of the DIN 7 connector on the Roomba. Table 1 shows the pin map of J1 connector on the RooStick board.

Note: The pins with the same names on RooStick and Roomba should be directly connected together. Make sure not to switch the RXD and TXD signals or the GND and DD signals.

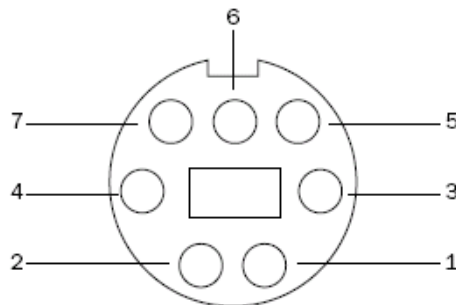

Figure 2. Pin-out connector of the RooStick. Mirrors input for SCI port. Refer to the Roomba SCI Manual for more information.

Pin #	Roo232 Signal Name	IO Direction	Explanation
1	Vpwr (15.6V)	Power In (10 – 25 V)	Unregulated Power
2	Vpwr (15.6V)	Power In (10 – 25 V)	Unregulated Power
3	TXD	Output (0 – 3.3 V)	Transmit Signal
4	RXD	Output (0 – 3.3 V)	Receive Signal
5	GND	Ground (0V)	Ground
6	GND	Ground (0V)	Ground
7	DD	Output (0 – 3.3 V)	For waking up Roomba

Table 1. Pin Map of J1 Connector on RooStick

3. **Troubleshooting FAQ**

Q. *What commands can I send Roomba?*

- A. The Roomba SCI Interface includes basic functionality which makes it ideal as a robotics platform. The documentation explains the already available SCI commands that can be sent to Roomba - http://www.roombadevtools.com/productcart/pc/docs/docs_roombasci.pdf. We highly recommend you read the SCI documentation.

Q. *Why doesn't Roomba respond to my commands?*

- A. Make sure your Roomba has the SCI (Serial Command Interface). Roombas manufactured before October 24th, 2005 do not come with the built-in SCI. To determine when your Roomba was manufactured, refer to the bar code underneath the battery of your Roomba. The following page shows how - http://www.roombadevtools.com/productcart/pc/content_docs_upgrade.asp

Q. *My Roomba was manufactured before October 2005. What should I do?*

- A. Don't worry! Roombas may be upgraded to obtain the SCI. Both RoombaDevTools and iRobot carry OSMOs which enable your pre-October 2005 Roomba to have the Serial Command Interface. Refer to "Upgrading an existing Roomba with an OSMO Hacker" on the following page - http://www.roombadevtools.com/productcart/pc/content_docs_upgrade.asp to determine which OSMO is needed.

Q. *Where can I find existing programs that allow me to interact with Roomba?*

- A. You can often find programs that people have already written under the software section of our webpage - <http://www.RoombaDevTools.com>. In addition, there are links to programs that other people have written in our Community Projects section. Be advised that the software and source code is provided "as is" and we do not guarantee nor warranty the software below in any manner. As such, any Telnet or similar type programs will work on any platform of your choosing. For more information on how to communicate with Roomba, please download the Roomba SCI Documentation.